

ORBOT VIBE



WARRANTY

All ORBOT equipment has been carefully tested and inspected at our USA factory. ORBOT Vibe machines are guaranteed for one year from the date of original purchase against defects or workmanship made during manufacture. Within the guarantee period we undertake at our discretion, to repair or replace any part found to be defective, free of charge to the purchaser **with subject to the following conditions:**

Claims made under the terms of the guarantee must be supported by the original invoice issued at the time of sale along with the machine serial number.

For claims under this guarantee contact the supplier from whom you've purchased the product who will arrange the appropriate action. Do not initially return the product as this could lead to transit damage.

Neither ORBOT nor its distributors will be held responsible for any incidental or consequential loss.

This guarantee does not cover:

- Periodic maintenance, repair or replacement of parts due to normal wear and tear.
 - Damage caused by accident, misuse or neglect, fire or the fitting of other than genuine ORBOT parts.
 - Defects in other than genuine ORBOT parts, repairs, modifications or adjustments made by other than an ORBOT service engineer or authorized service dealer.
 - Costs and risks of transport relating directly or indirectly to the guarantee of this product.
 - Consumable items such as brushes, drivers, velcro discs, gliders, pads and so forth.
- ORBOT has a policy of continual product development and we reserve the right to alter specifications without prior notice.

MACHINE DATA

Model:	_____
Serial:	_____
Date of Purchase:	_____
Dealer:	_____
Address:	_____
Phone Number:	_____
Sales Representative:	_____

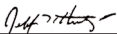
EC Declaration of Conformity	CE
Machine Type: Floor Model: Orbot Vibe	
This Machine is in conformity with the following EU directives:	
- Machinery Directive: 2006/42/EC	
- Electro Magnetic Compatibility Directive: 2004/108/EC	
- In conformity with 2006/95/EC	
Applied harmonized standards: EN 60335-1, EN 60335-2-67	
HOS GmbH Hruby Orbital Systems Kleiststraße 7, 10787 Berlin Date: 02/08/2010	 _____ Jeffrey Hruby CEO

Warranty	2
EC Declaration of Conformity	
How to Use This Manual	4
Safety - Important Instructions	5 - 7
Technical Details	8
Operation	9 - 16
Unpacking and Initial Operations	9
Pre-Run Inspection	
Adjusting Height	
Process of Cleaning	10
End of Application	
Storage	
Lifting and Carrying	11
Weight Kit Installation	
Brush Installation	12
Attaching and Removing the Driver Plates	
Accessories and Applications	13
Multi-Floor Velcro Driver Plate	
AgiClean Pad	
SuperZorb Pad	
UltraLift Pad	14
AkwaStrip Pad	
StoneFlash Pad	
Multi-Purpose Scrub Brush	15
Concrete Brush	
Operation/Maintenance (Application on Different Floors)	16
Carpet Cleaning	
Cleaning Hard Floors	
Cleaning the Machine	
Changing the Driver Grip Face	
Part Diagrams and Part Lists	17 - 23
Wiring Diagram	24
Notes	25

HOW TO USE THIS MANUAL

This manual contains the following sections:

- How to Use This Manual
- Safety
- Operations
- Maintenance
- Parts List

The HOW TO USE THIS MANUAL section will tell you how to find important information for ordering correct repair parts.

Parts may be ordered from authorized dealers. When placing an order for parts, the machine model and machine serial number are important. Refer to the MACHINE DATA box which is filled out during the installation of your machine. The MACHINE DATA box is located on the inside of the front cover of this manual.

The model and serial number of your machine is located on the left side of the handle, from the operators perspective.

The SAFETY section contains important information regarding hazardous or unsafe practices of the machine. Levels of hazards are identified that could result in product damage, personal injury, or severe injury resulting in death.

The OPERATIONS section is to familiarize the operator with the operation and function of the machine.

The MAINTENANCE section contains preventive maintenance to keep the machine and its components in good working condition. They are listed in this general order:

- Storage
- Maintenance
- Troubleshooting

The PARTS LIST section contains assembled parts illustrations and corresponding parts list. The parts lists include a number of columns of information:

- REF – column refers to the reference number on the parts illustration.
- PART NO. – column lists the part number for the part.
- PRV NO. – reference number.
- QTY – column lists the quantity of the part used in that area of the machine.
- DESCRIPTION – column is a brief description of the part.
- SERIAL NO. FROM – If this column has an (*) and a Reference number, see the SERIAL NUMBERS page in the back of your manual. If column has two asterisk (**), call manufacturer for serial number. The serial number indicates the first machine the part number is applicable to. The main illustration shows the most current design of the machine. When a boxed illustration is shown, it displays the older design.
- NOTES – column for information not noted by the other columns.

NOTE: If a service or option kit is installed on your machine, be sure to keep the KIT INSTRUCTIONS which came with the kit. It contains replacement parts numbers needed for ordering future parts.

NOTE: The manual part number is located on the lower left corner of the front cover.

IMPORTANT SAFETY INSTRUCTIONS

When using this machine, basic precautions must always be followed, including the following:

READ ALL INSTRUCTIONS BEFORE USING THIS MACHINE.

WARNING

To reduce the risk of fire, electric shock, or injury:

- Use only indoors. Do not use outdoors or expose to rain.
- Use only as described in this manual. Use only manufacturers recommended components and attachments.
- If the machine is not working properly, has been dropped, damaged, left outdoors, or dropped into water, return it to an authorized service center.
- Do not operate the machine with any openings blocked. Keep openings free of debris that may reduce airflow.
- Machine can cause a fire when operating near flammable vapors or materials. Do not operate this machine near flammable fluids, dust or vapors.
- This machine is suitable for commercial use such as: in hotels, schools, hospitals, factories, shops, and offices for more than normal housekeeping purposes.
- Maintenance and repairs must be done by qualified personnel.
- During operation, use caution around other persons, especially children.
- The machine shall only be operated by instructed and authorized persons.
- When leaving unattended, unplug the machine.
- Do not handle the plug or machine with wet hands.
- Do not unplug machine by pulling on cord. To unplug, grasp the plug and not the cord.
- Do not use with damaged cord or plug. Follow all instructions in this manual concerning grounding the machine.
- Do not pull or carry by cord, use cord as a handle, close a door on cord, or pull cord around sharp edges or corners.
- Do not pull/run machine over cord. Keep cord away from heated surfaces.
- Connect to a properly grounded outlet. See Grounding Instructions.
- If the supply cord is damaged it must be replaced by an authorized service agent.
- Unplug before cleaning or servicing.
- Operational hazard may occur when running the machine over the supply cord.
- This appliance has been designed for use with pads specified by the manufacturer. The fitting of other pads may affect its safety.
- This machine is for dry use only and shall not be used or stored outdoors in wet conditions
- Moving Parts - To reduce the risk of injury, unplug before servicing.

READ AND SAVE THESE INSTRUCTIONS

SAFETY

The following symbols are used throughout this guide as indicated in their descriptions:

HAZARD INTENSITY LEVEL

There are three levels of hazard intensity identified by signal words -**WARNING**, **CAUTION**, and **FOR SAFETY**. The level of hazard intensity is determined by the following definitions:



WARNING - Hazards or unsafe practices CAN result in severe personal injury or death.



CAUTION - Hazards or unsafe practices which could result in minor personal injury or product or property damage.

FOR SAFETY: To identify actions which must be followed for safe operation of equipment.

Report machine damage or faulty operation immediately. Do not use the machine if it is not in proper operating condition. The following is information that signals some potentially dangerous conditions to the operator or the equipment. Read this information carefully. Know when these conditions can exist. Locate all safety devices on the machine. Please take the necessary steps to train the machine operating personnel.

FOR SAFETY:

DO NOT OPERATE MACHINE:

- Unless trained and authorized.
- Unless Operation Guide is read and understood.
- In flammable or explosive areas.
- In areas with possible falling objects.

WHEN SERVICING MACHINE:

Avoid moving parts. Do not wear loose clothing, jackets, shirts, or sleeves when working on the machine. Use only manufacturer approved replacement parts.

GROUNDING INSTRUCTIONS 120V

THIS PRODUCT IS FOR COMMERCIAL USE ONLY

ELECTRICAL:

In USA this machine operates on a 15 amp nominal 120V, 60 hz, A.C. power circuit. The amp, hertz, and voltage are listed on the data label found on each machine. Using voltages above or below those indicated on the data label will cause serious damage to the motors.

GROUNDING INSTRUCTIONS:

This appliance must be grounded. If it should malfunction or break down, grounding provides a path of least resistance for electric current to reduce the risk of electric shock. This appliance is equipped with a cord that has an equipment-grounding conductor and grounding plug. The plug must be inserted into an appropriate outlet that is properly installed and grounded in accordance with all local codes and ordinances.

For use on a nominal 120 volt circuit with a grounded plug that looks like the plug in FIGURE A. A temporary adaptor that looks like the adaptor in FIGURE C may be used to connect this plug to a 2-pole receptacle as shown in FIGURE B, if a properly grounded outlet is not available. The temporary adaptor should be used only until a properly grounded outlet (FIGURE A) can be installed by a qualified electrician. The green colored rigid ear, lug or similar that extends from the adaptor must be connected to a permanent ground such as a properly grounded outlet box cover. Whenever the adaptor is used, it must be held in place by a metal screw.

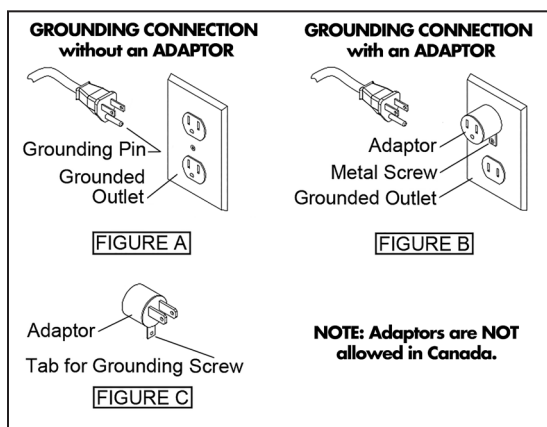

⚠ WARNING

Improper connection of the equipment-grounding conductor can result in electric shock. Check with a qualified electrician or service person if you are in doubt as to whether the outlet is properly grounded. Do not modify the plug provided with the appliance - if it will not fit the outlet, have a proper outlet installed by a qualified electrician.

SAFETY LABEL LOCATION

If at any time the safety labels become illegible, contact your authorized representative for prompt replacement.

TECHNICAL DETAILS

ITEM	SPECIFICATIONS
Motor	1HP, 1400W, 6-11amp, 100-240V, 50/60Hz
Dual Speed	1725 RPM (Orbital), 80 RPM (Rotational)
Drive Diameter	17" (43.18 cm)
Wheel Diameter	10" (25.4 cm)
Quick-Connect Power Cord	50 ft. (15m)
Solution Tank Capacity	4 Gallon (15.1L)
Pump	90 PSI (6.2 BAR)
Noise Level	59 dB
Height	48.8" (123.9 cm)
Length	28.19" (74.1 cm)
Weight	95 Lbs./43.09 Kg

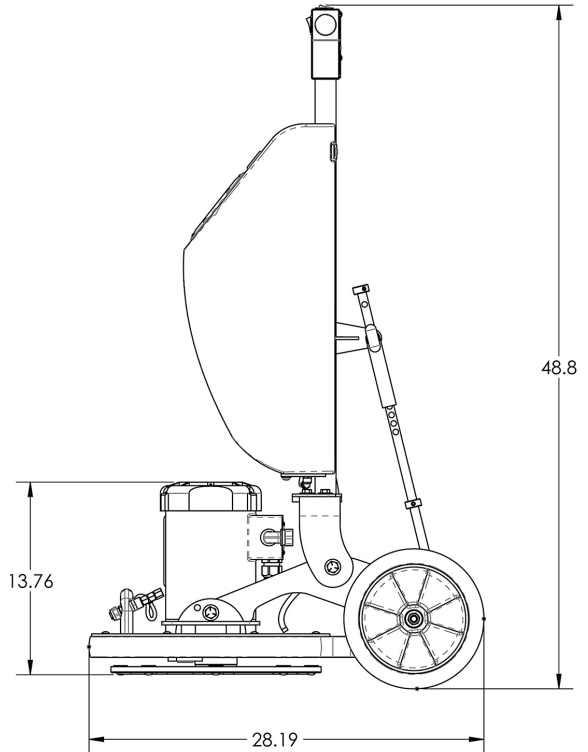
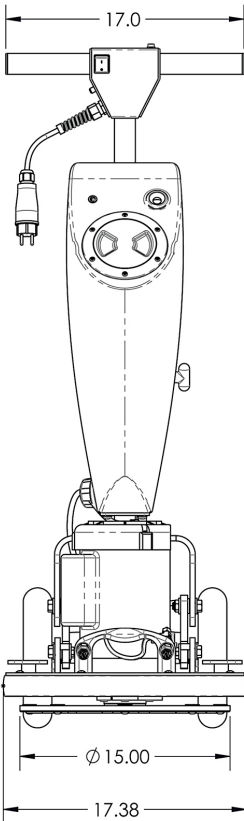

Unpacking and Initial Operations

Open shipping box (both sides). Remove packaging material and roll machine out of the box.

Fill the tank with water. You may add a cleaning solution with prescribed mixing ratio.

Pre-Run Inspection

Before each use, inspect for cracks, tears or excess wear. If the machine or accessory is dropped, inspect for damage. Then repair or replace, if necessary, before use.

Tilt head back and place the foot of bumper on the ground. Choose a pad for the appropriate application. Center the pad on driver plate. Then position handle in a lower position and push slowly forward until machine base tilts towards the ground.



! CAUTION

Make sure to put the wheels back on the ground in time to avoid the base from falling on the ground. This might cause damage!

Check that the power switch is in the "off" position.

Adjusting Height

Set handle position to desired height by pulling and releasing the black knob with the left hand.

While holding the black knob out, raise or lower the handle frame with your right hand.

To secure handle frame, release the black knob so that it locks firmly into one of the holes provided.

Position "0" is off and position "1" is on.



! CAUTION

Make sure a suitable pad or brush is mounted before starting the machine. The immediate contact to floor and driver plate, without a pad, can lead to serious damage to the floor and/or the machine.

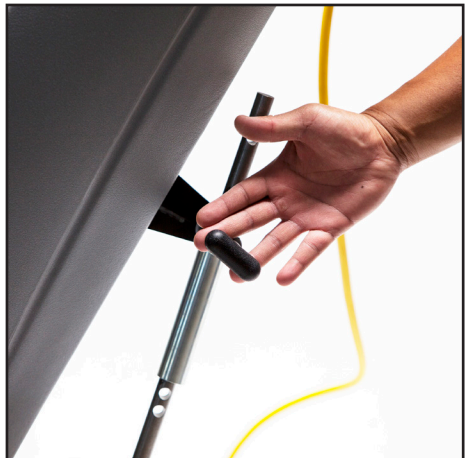

OPERATION

Process of Cleaning

For effective floor cleaning, move the machine forward and backwards. It is recommended to wet the floor as you move the machine forward, releasing the solution button when you move the machine backwards.

To increase the pressure and cleaning effect on certain floor types like tile and grout, you can lift the machine frame up, raising the wheels off the ground. When lifting the wheels off the ground the full weight of the machine lies on the machine base.



CAUTION

Make sure the surface to be cleaned is not damaged by the increase in pressure. Omit this measure on very sensitive floors.

End of the Application

Turn off the machine by putting the on/off switch to "O". If a cleaning solution was used, fill solution tank with water and spray out system for 30 seconds. Make sure to not let solution come in contact with the motor.



Storage

To avoid damage to the handle frame, do NOT lay machine frame on floor as done with other traditional cleaning equipment.

1. Remove the pad from the driver plate by pulling it down firmly. **2.** Put machine frame in an upright position by pulling the black knob with the left hand and move the handle frame upwards with the right hand. The black knob should lock firmly in the top hole.

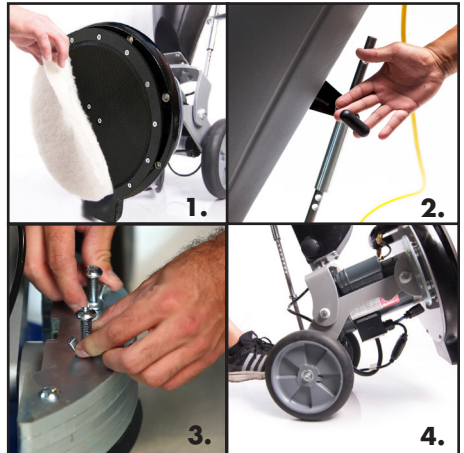

CAUTION

3. To allow for easy transportation of the machine, remove the weight kit if used.

4. To easily roll machine, place foot on the back wheel axle and pull handle towards you. Moving machine similar to a dolly. Always store with the base in the upright position.

Lifting and Carrying

Without a ramp, we recommend 2 people to lift machine in and out of vehicle setting wheels down first, then base. Lock handle in a lower position. Make sure that the machine base rests on a pad, so that the grip surface of the driver plate does NOT get damaged or hooked onto a carpeted surface.



⚠️ WARNING

Do NOT grip too close to the machine base. If the base should flip upwards it can cause serious hand injury.

Lift machine with a back-friendly posture. And then secure machine firmly so it will not move.

Grip the machine from each side as shown.



Weight Kit Installation

Place the weight kit (40 lbs.) on top of the mounting plates located on the sides of the machine base.

Put the 4 screws into the holes provided on the weight plates and fasten by turning clockwise.

Once the screws have threaded at least 5 full turns, tighten wing nuts by turning clockwise, until the weights fit securely to the base.

⚠️ CAUTION

Make sure that the weights are securely attached to the base. Loose weights can cause serious damage.

For storage and transport, we recommend removing the weight kit. The machine can be transported more easily without the weights.



OPERATION

Brush Installation

Put the machine base in an upright position, sitting on the foot of the bumper. Remove the driver plate by removing the four countersink screws in the center of the plate using an electric screwdriver.



! WARNING

It is important to only use a # 3 Phillips head screwdriver bit. Smaller bit sizes can damage the screw heads and leave sharp edges, which can tear or snag the pads. Damaged screws can cause further damage. Mount the brush with the same countersink screws used for mounting the driver plates.

- **NOTE:** Tighten the screws sufficiently to avoid disengagement of the brush from the machine during operation.

To avoid stripping the screws, do NOT over tighten. An electric screwdriver with a clutch will ensure that stripping will NOT occur.



Attaching and Removing the Driver Plates

Put the machine base in an upright position, sitting on the foot of the bumper. Remove the driver plate by removing the four countersink screws in the center of the plate using an electric screwdriver.

Attach a driver plate to the machine base by lining up the holes of the driver plate with the appropriate threads of the bearing retainer ring. It is recommended to align the threads of the bearing horizontally to the ground.

Put the 4 countersink screws through the holes of the driver plate and first screw them into the bearing retainer ring threads manually. Then, tighten the screws with an electric screwdriver.

- **NOTE:** Tighten the screws sufficiently to avoid disengagement of the driver plate from the machine base during operation. To avoid stripping the screws, do NOT over tighten. An electric screwdriver with a clutch will ensure that stripping will NOT occur.



ACCESSORIES AND APPLICATIONS

⚠ WARNING

Never store the accessories in wet conditions. Keep the accessories away from extreme heat and from chemicals.

Multi-Floor Velcro Driver Plate

Exclusively use designated driver plates only. Using other driver plates will damage the machine and its mechanical action. Driver plates are fastened on the machine base with four countersink screws. The 17" driver plate supplied is suitable for all pads on textile and hard floor applications. Pads can be easily attached and removed from the driver disc.

⚠ WARNING

Never place driver on carpet without a pad attached. May cause damage to the floor.

AgiClean Pad

The beige AgiClean pad is made of a special blend of fibers and latex that allows gentle cleaning of heavily soiled short-pile carpets as well as scrubbing of hard floors. Attach the AgiClean pad by centering onto the driver plate. AgiClean pads, used on both sides, cleans an approximate area of 3,000 sq. ft. (280m²), depending on floor type and level of soil. Rinse the AgiClean pads after each use with clean water.

SuperZorb Pad

Our exclusive SuperZorb pad is made of a special cotton and polyester blend. One of the primary components that help to extract an essential amount of soil from the carpet fibers. They also play an important role to achieve fast dry times. SuperZorb pads, used on both sides, cleans approximately 30,000 sq. ft. (2800m²) with up to 100 washes. This of course depends upon floor type and level of soil. SuperZorb pads are also machine washable. Allow to air dry.

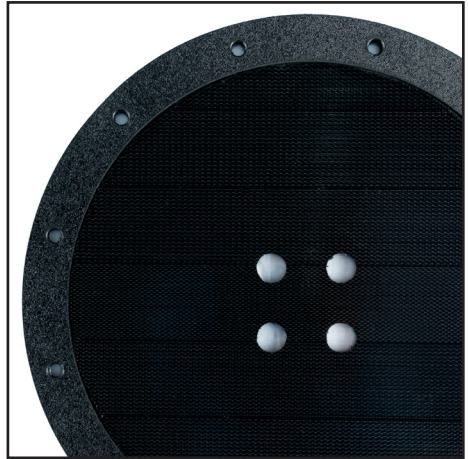

SUPERZORB
SOIL EXTRACTION PADS

OPERATION

UltraLift Pad

The UltraLift pad can be used on stone, concrete, VCT, marble and porous surfaces.

Each pad can clean an approximate area of 4,000 sq. ft. (372m²) depending on floor type and level of soil.

AkwaStrip Pad

The AkwaStrip pad is a chemical free stripping pad made of a unique material filled with diamonds. Used for deep cleaning and to remove wax off of vinyl, VCT, linoleum, wood, safety tiles and more. Used on both sides, can clean approximately 2,500 to 5,000 sq. ft. (230 to 460m²), depending on floor type and the level of wax/soil. Thoroughly rinse with clean water after use.

StoneFlash Pads

Our newly redesigned StoneFlash pads are part of a 5 step system for grinding, honing and polishing marble, terrazzo, travertine, limestone and more.

Each pad cleans an approximate area of 5,000 sq. ft. (460m²) depending on floor type and level of soil.

- **NOTE:** StoneFlash pads require the use of the ORBOT Weight Kit (sold separately).



Multi-Purpose Scrub Brush

The bristles of the brush are made of high quality nylon. The unique brush design is ideal for cleaning tile and grout, smooth concrete, rubber flooring and other microporous surfaces such as porcelain and safety tiles. It can also be used for any other hard surfaces.

⚠ CAUTION

The use of the multi-purpose brush may splash in certain applications. Take appropriate measures or use a splash guard to prevent the wetting of walls and other obstacles.

Rinse the brush as needed with clean water after each use. Depending on usage and care, you can use the multi-purpose brush for many years.

- **NOTE ON STORAGE:** Never store the multi-purpose brush with the bristles down. This can deform the bristles, damage the brush, and reduce the cleaning performance.

You can bring deformed bristles back into their original form by heating them with a heat gun.

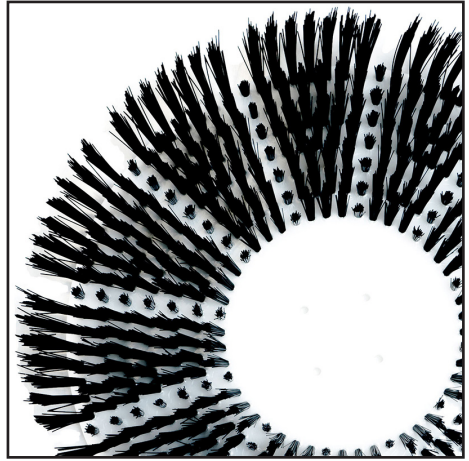

Concrete Brush

Our concrete brush is designed for outside concrete and other rough surfaces. It is great for cleaning walkways with minimal water.

⚠ WARNING

Never use the concrete brush on any other floor other than specified outside concrete or rough surfaces, as this brush will cause serious damage to all other flooring.

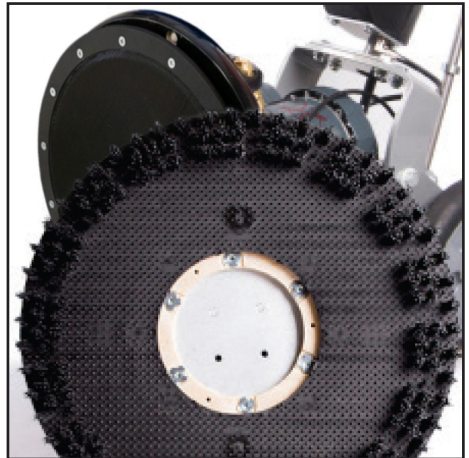

OPERATION / MAINTENANCE

APPLICATION ON DIFFERENT FLOORS

Carpet Cleaning

Vacuum the carpet thoroughly before cleaning. Large dirt particles are removed, allowing the application to be more effective.

Apply solution while moving forward. Clean by going forward and backwards 2 to 3 times, while applying solution on the first pass in order to keep the drying time low. Depending on soil level and nature of the carpet, this process can be shortened or extended. As required, carpets can be vacuumed again after cleaning.



Cleaning Hard Floors

Remove dust and coarse dirt from the surface before cleaning. Choose a suitable pad according to the application. Place the pad in the center of the driver. Gently lower the head on to the floor. Moving forward and backwards while adding water to the surface. Use cleaning solution as needed. Depending on soil contamination and floor type, this process can be shortened or extended.



MAINTENANCE

Cleaning the Machine

Clean the machine and bearing with a soft cloth and a neutral pH cleaner. Regular cleaning of the bearing is required to prevent build up that will cause it to seize up.

Changing the Driver Grip Face

Remove the 10 outer screws that fasten the grip face disc on the driver plate. To save time, use an electric screwdriver with a #3 Phillips head bit.

! WARNING

The #3 Phillips head bit is slightly larger than standard size. It is important that you are using a #3 Phillips head bit, as smaller bits can damage the screw heads and produce sharp edges which can damage the cleaning pads. Attach a new grip face disc to the driver plate using the 10 screws.

Make sure that the screws are very tight, not loose. If the screws are too loose, it can cause damage to the grip face disc. Ensure that the 4 holes in the middle of the grip face disc are aligned with the screws located on the driver plate. An exact alignment allows an easy removal and installation of the driver plate.

SPRAY NOZZLE ASSEMBLY

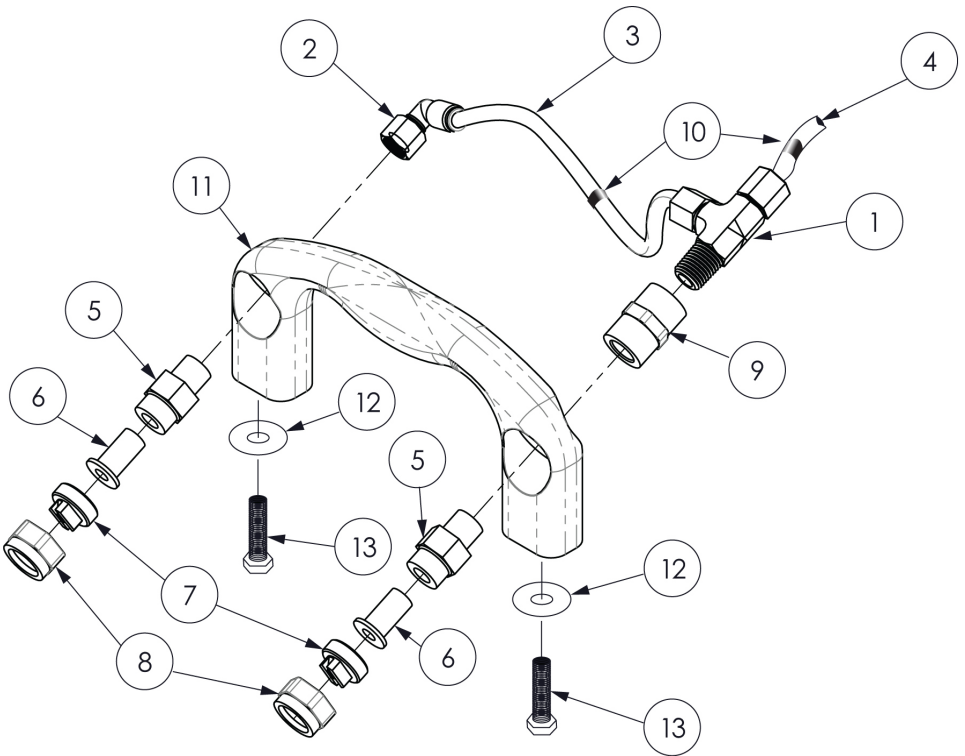

ITEM NO	PART NUMBER	DESCRIPTION	QTY.
1	3019	FITTING, TEE, SPRAY NOZZLE	1
2	3021	ELBOW, 90°, SPRAY NOZZLE	1
3	3022-02	HOSE, SPRAY HANDLE, 1/4" X 5"	1
4	05-004	HOSE, SPRAY NOZZLE, PUMP, 1/4" X 26.5"	1
5	3016	SPRAY JET BODY	2
6	30155	CHECK VALVE STRAINER	2
7	3014	NOZZLE, SPRAYER	2
8	3017	SPRAY CAP	2
9	3020	COUPLER, FLOW JET	1
10	3019-01	SLEEVE, COMPRESSION	2
11	20-010	SPRAY HANDLE	1
12	3035	WASHER, FLAT .38 X .06T X 1.0 OD	2
13	01-019	SCREW, HEX CAP 312-18 X .875	2

PARTS

HANDLE / FRAME ASSEMBLY

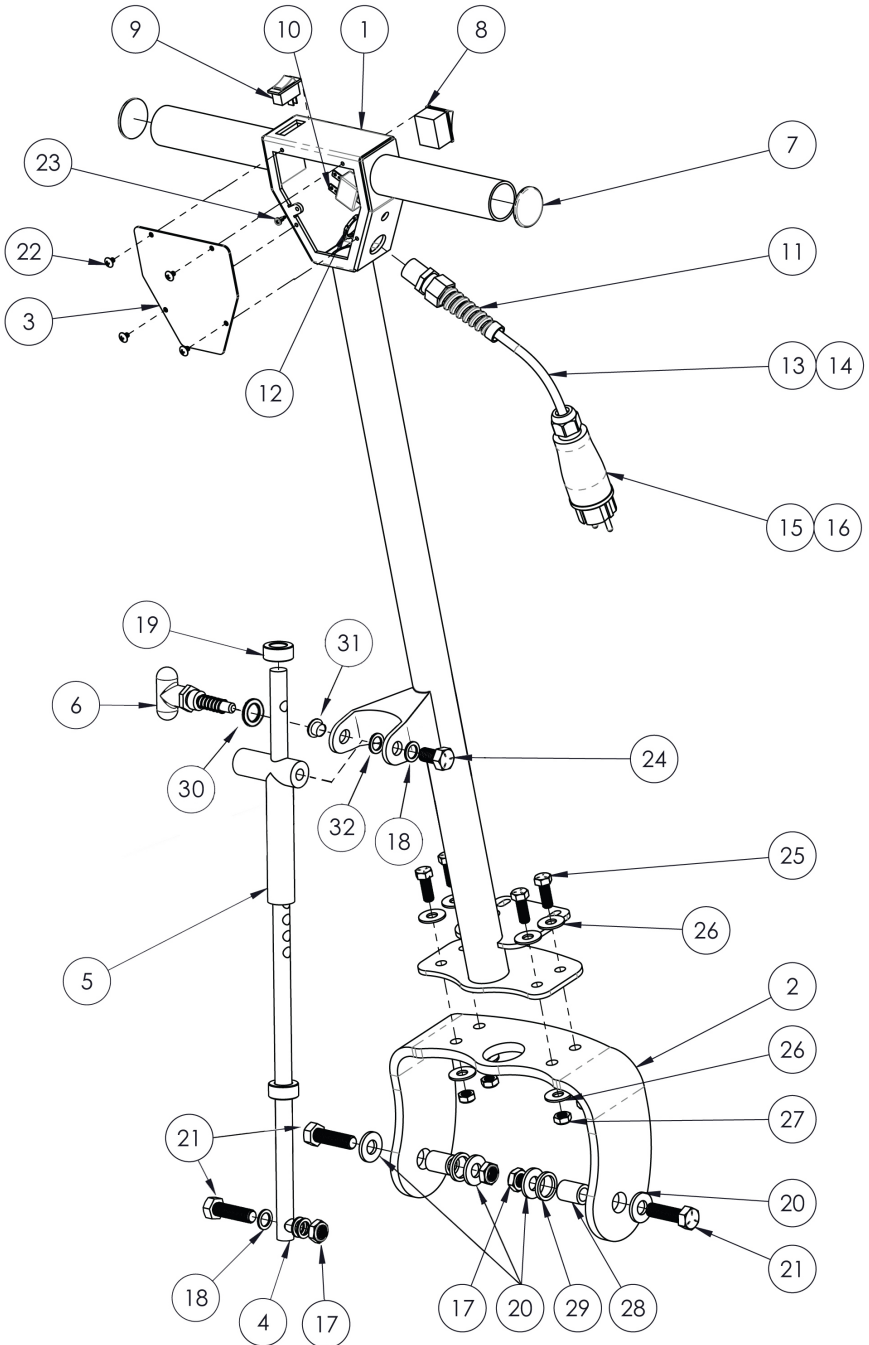

HANDLE / FRAME ASSEMBLY

ITEM NO	PART NUMBER	DESCRIPTION	QTY.
1	10-002	WELD ASSY, HANDLE	1
2	10-009	FORK	1
3	10-001	COVER, ELECTRICAL BOX	1
4	10-006	ROD, HANDLE ADJUST	1
5	10-005	WELD ASSY, PULL LATCH	1
6	1025	PULL LATCH	1
7	08-001	COVER, TUBE HANDLE, 1.5 DIA	2
8	1005-03	SWITCH, ROCKER, ON/OFF, DOUBLE POLE	1
9	1007	SWITCH, ROCKER, SPRAYER, DOUBLE POLE	1
10	03-003	BREAKER, 20A 125/250VAC 32VDC	1
11	1018	STRAIN RELIEF, POWER CORD	1
12	1014	LOCK NUT, ELECTRICAL PANEL, .5-14	1
13	1033-09	HANDLE CORD / PIGTAIL, 230V (EU), WITH ITEMS 11 & 15	1
14	1033-19	HANDLE CORD / PIGTAIL, YELLOW (US), WITH ITEMS 11 & 16	1
15	1033-08	PLUG, MALE, 220V (EU)	1
16	1033-01	PLUG, MALE, 110V (US)	1
17	4011	HEX NUT, LOCK, .5-13 X .75W X .312	3
18	01-009	WASHER, NYLON, .50 ID X .75 OD X .06 T	3
19	1027	SHAFT COLLAR, SET SCREW, .63 ID X 1.1 OD X .5	2
20	4010	WASHER PLASTIC, .50 ID X 1.125 OD X .125 THK	4
21	01-042	SCREW, HEX CAP, .5-13 X 1.75"	3
22	1012	SCREW, MACHINE, 8-32 x .25	4
23	1032	SCREW, PHP, DRILLING, 8-32 x .38"	1
24	01-007	SCREW, HEX CAP, .5-13 X .875"	1
25	01-044	SCREW, 3/8"-16 X 1"	4
26	3035	WASHER, FLAT .38 X 1 OD X .06 THK	8
27	01-045	LOCK NUT, 3/8"-16	4
28	4002-2	BUSHING, PLASTIC, .75" X .5" X 1"	2
29	01-046	WASHER, NYLON PLASTIC, .812" ID, 1.057" OD	2
30	01-067	WASHER, NYLON PLASTIC, .765" ID, 1.312" OD X .62	1
31	10-015	PIVOT BUSHING, LOCKING HANDLE, VIBE	1
32	4010	WASHER PLASTIC, .50 ID X 1.125 OD X .125 THK	1

PARTS

SOLUTION TANK ASSEMBLY

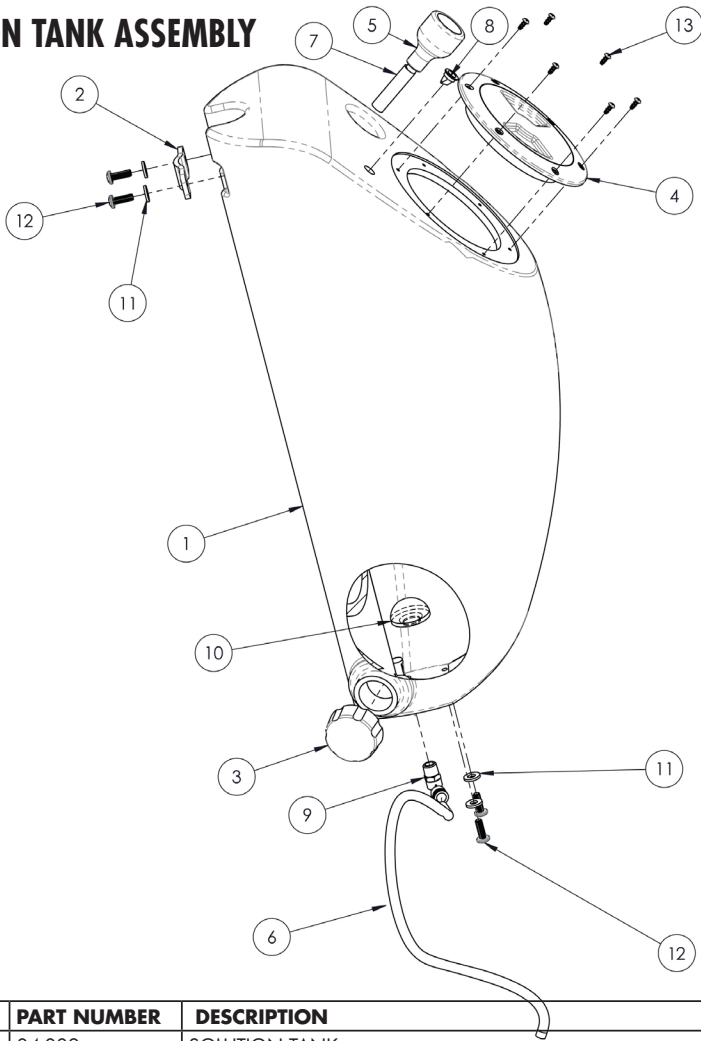

ITEM NO	PART NUMBER	DESCRIPTION	QTY.
1	04-002	SOLUTION TANK	1
2	20-001	BRACE, TANK	1
3	04-004	CAP, DRAIN, 2"	1
4	04-003	LID, TANK	1
5	04-005	FAUCET FILL	1
6	05-002	TUBING, .375 OD X .25 ID, BLACK	1
7	05-001	TUBING, FAUCET FILL, 26"	1
8	04-006	VALVE, DUCKBILL	1
9	02-001	FITTING, ELBOW, 3/8" OD X 1/4" NPT	1
10	2017	STRAINER, FILTER	1
11	01-011	WASHER, FLAT, .25 ID X .625 OD X .06 THK	4
12	01-010	1/4"-20 THREAD 3/4" LONG	4
13	01-012	ROUNDED HEAD THREAD-FORMING SCREW	6

WHEEL KIT ASSEMBLY

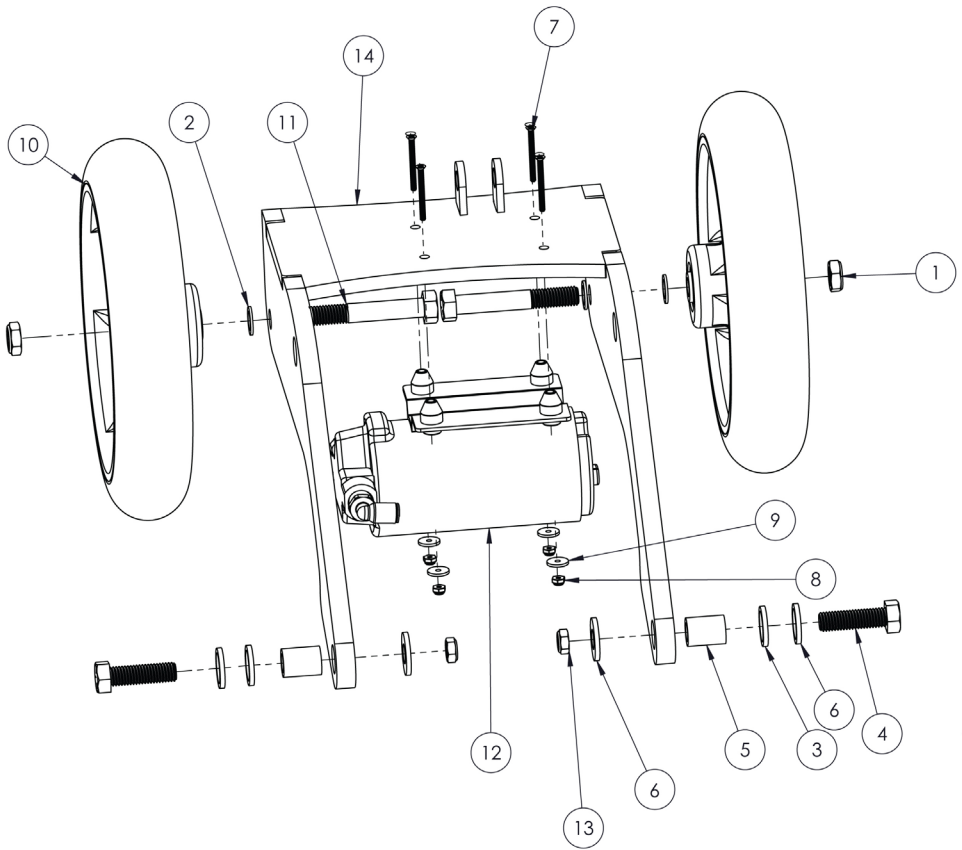

ITEM NO	PART NUMBER	DESCRIPTION	QTY.
1	4011	HEX NUT, LOCK, .5-13 X .75W X .312	2
2	4010	WASHER PLASTIC, .5 ID X 1.125 OD X .125 THK	2
3	01-046	WASHER, NYLON, 0.812" ID X 1.057" OD	2
4	01-042	SCREW, HEX CAP, 1/2"-13. 1-3/4" LONG	2
5	4002-2	BUSHING, PLASTIC, .75" X .5" X 1"	2
6	4010	WASHER PLASTIC, .5 ID X 1.125 OD X .125 THK	2
7	01-043	SCREW, 6-32 X 1-1/2", PUMP MOUNT	4
8	2013	NUT 6-32, HEX NYLOCK	4
9	2014	WASHER, PUMP MOUNT	4
10	4003	WHEEL, 10"	2
11	01-031	SCREW, HEX CAP, .5-13 X 3.25	2
12	2010	PUMP (DOMESTIC)	1
13	4011	HEX NUT, LOCK, .5-13 X .75W X .312	2
14	40-005	WELD ARMS ASSEMBLY	1

PARTS

MOTOR & BASE ASSEMBLY

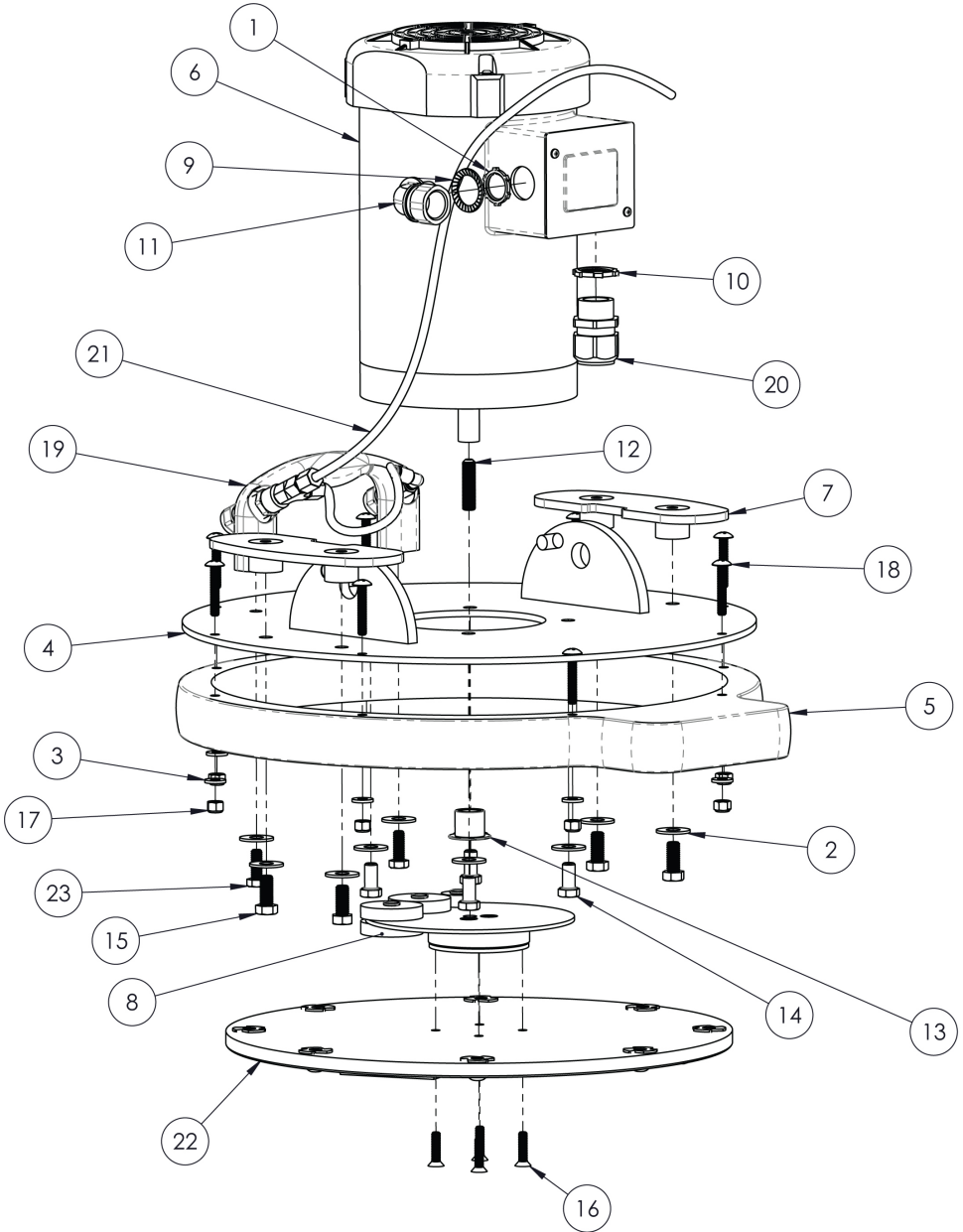

MOTOR & BASE ASSEMBLY

ITEM NO	PART NUMBER	DESCRIPTION	QTY.
1	1014	LOCK NUT, 1/2", ELECTRICAL BOX	1
2	3035	WASHER, FLAT .38 X .06T X 1.0 OD	10
3	01-011	WASHER, FLAT, .25 ID X .625 OD X .06 THK	8
4	3046	BASE, WELD ASSY	1
5	3001	BUMPER, 17 INCH	1
6	3023	MOTOR, 1HP	1
7	30-007	SPACER PLATE, WELD ASSY	2
8	3026	ASSY, COUNTERWEIGHT	1
9	3023-02	WASHER, SERRATED, 3/4", CORD GRIP	1
10	3030	LOCK NUT, 1", ELECTRICAL BOX	1
11	3029	ELBOW, 3/4", ELECTRICAL BOX	1
12	3024	SCREW, SOCKET SET, .38-24 X 1.50	1
13	3025	SHAFT SUPPORT	1
14	3034	SCREW, HEX HEAD, .38-16 X .75	4
15	01-017	SCREW, HEX CAP, .38-16 X .5	4
16	3047	SCREW, FHPM, .25-20 X 1.0	4
17	3003	HEX NUT, LOCK, .25-20 X .438W X .313H	8
18	01-021	SCREW, THPM, .25-20 X 1.5, 18-8 SST	8
19	20-010	SPRAY HANDLE	1
20	3031	CORD GRIP, 1", ELECTRICAL BOX	1
21	05-004	HOSE, SPRAY NOZZLE, PUMP, 1/4" X 26.5"	1
22	MFDKIT17	17" MULTI-FLOOR DRIVER KIT	1
23	3006	SCREW, HEX CAP, .312-18 x .75	2

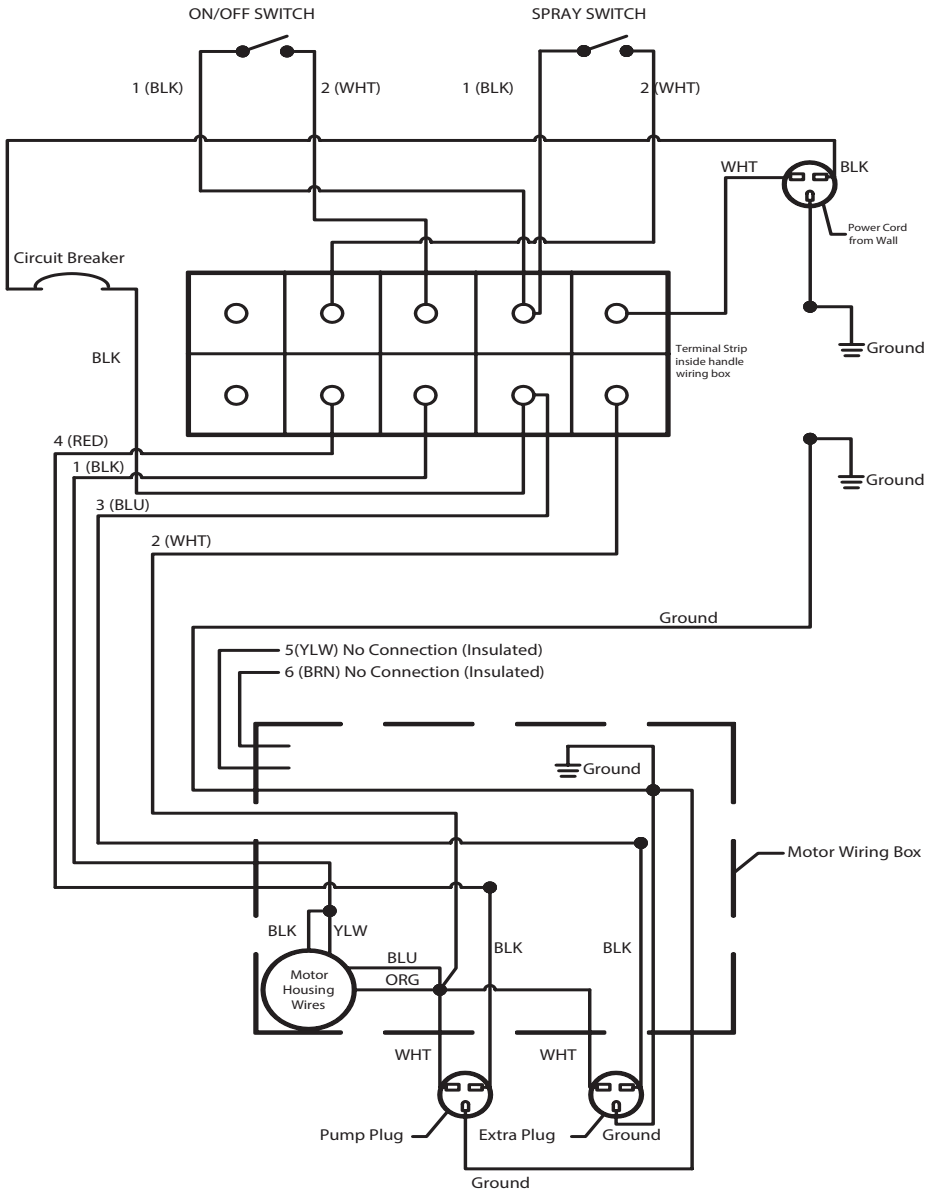

ORBOT

ORBOT

ORBOT

ORBOT

CLEAN. RENEW. AMAZE.

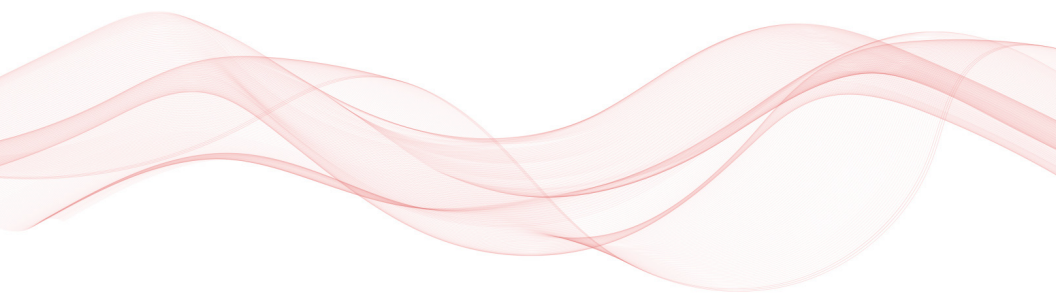

ORBOTUSA.COM

3275 Corporate View, Vista, CA 92081

P: 760.936.8054

E: CustomerService@orbotusa.com